

\* Doppia parete  
Double skin  
Double paroi  
Doppelwandig  
Dobla pared

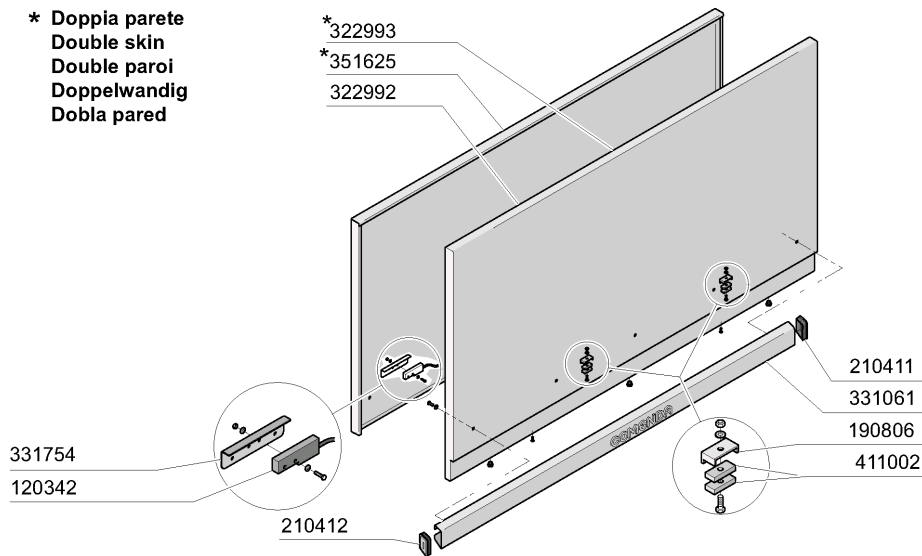

CODE	DESCRIPTION
120342	DOR MAGNETIC SWITCH
180651	ACS/ACRS DOOR RAIL
190154	BRAKE
190806	MAGNET HOUSING
190906	CURTAIN IN/OUT 620X480
200478	SELF-ADHESIVE GASKET 65X4
200935	GASKET
210404	BLACK RUBBER FOOT S90 NE SE
210411	RIGHT PLUG FOR ACR/AC HANDLE
210412	LEFT PLUG FOR ACR/AC HANDLE
320691	PLATE
322992	DOOR AC-ACR 1300MM
322993	INSULATED DOOR AC-ACR1300
323303	BRACKET FOR DOOR 1300
323477	TRAVERSA SOST.VASCHE AC/ACR
330715	UPPER BRACKET CURTAIN SNL-SE
331061	DOOR HANDLE AC-ACR 1300MM
331116	DOOR SECURITY HOOK
331754	DOOR MICRO SWITCH BRACKET FOR
331755	HOOK FOR DOOR SUPPORT
332377	SQUADR.AGG.PANN.POST.AC/R/2001
340422	SHAFT FOR CURTAIN AC-ACR
341016	BRACKET FOR DOOR SECURITY HOOK
351625	INSUL.PANEL F.DOOR 1300 AC-ACR
351638	FRONT PANEL WITHOUT THERMOMET.
351654	PANEL LV
351663	PANEL LAV
351859	GUIDES SUPPORT
351941	BACK PANEL 400
351943	BACK PANEL 900
351985	BACK PANEL 600
411002	PERMANENT MAGNET 24X12
450220	SPRING
620222	COMPLETE ALUMINIUM LEGS

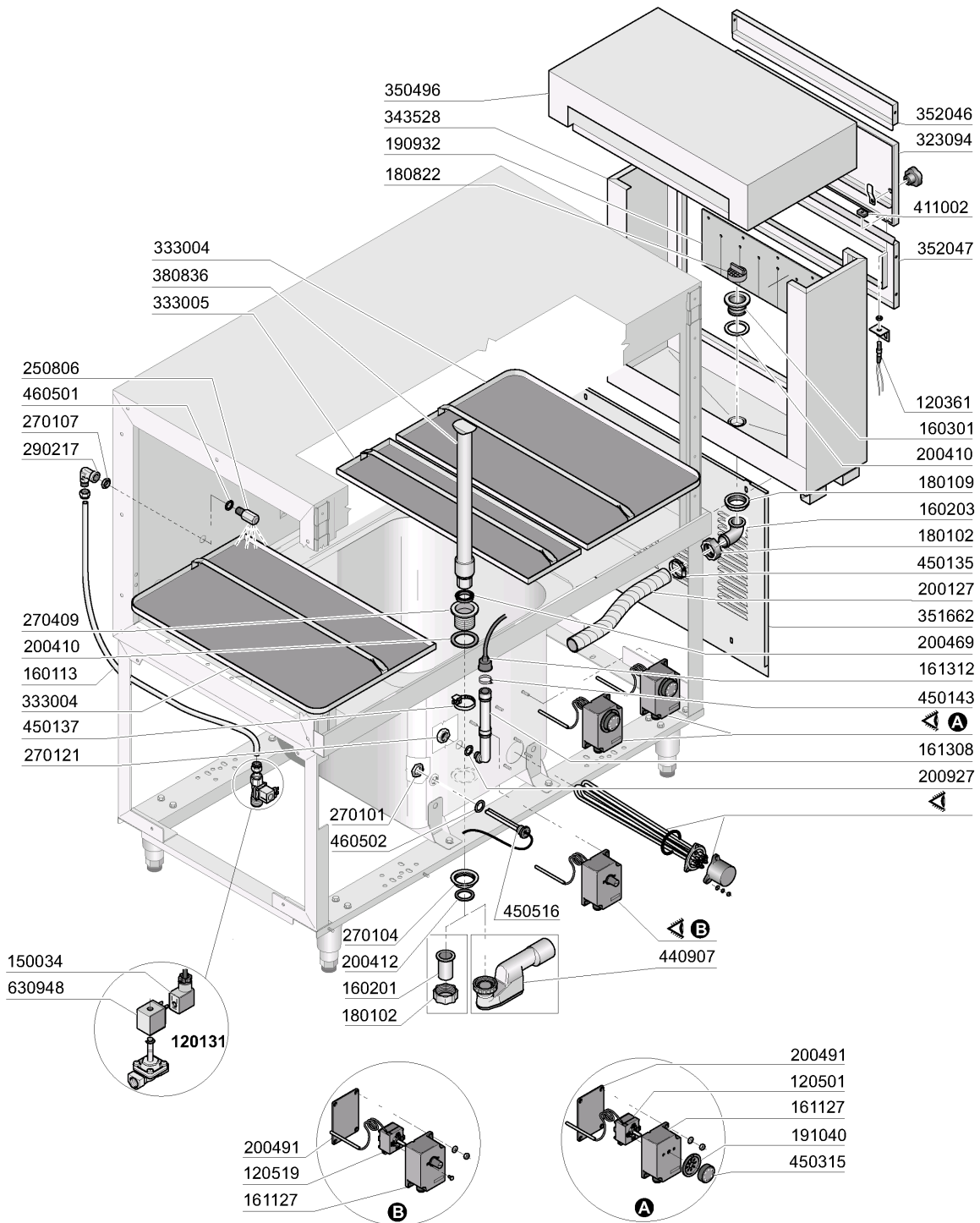

3 - Tank 1300

CODE	DESCRIPTION
120131	SOLE. L182Q31-ZB10A 1/2"24V
120361	SENSOR
120501	THERMOSTAT 30/90ØC
120519	SECURITY THERMOSTAT 95-125Ø
150034	CONNec.F.SOLEN.VALVE 122.09.N
160113	TUBE IN POL. RETIC. 12 EST
160201	ELBOW F.TANK INLET MOPLen
160203	ELBOW 1"1/2 N-S-F-C /DRAIN
160301	DRAIN OUTLET 1"1/2 C-S-N
161127	BOX FOR THERMOSTAT
161308	AIR CHAMBER C95-155
161312	HOSE FOR PRESSURE SWITCH C95-1
180102	DRAIN PIPE NUT 1"1/2 F45-55
180109	LOCK NUT 1 1/2"
180822	DRAIN FILTER FOR FC"HR"
190932	CURTAIN ENTRY LAV
191040	FRAME F.THERMOSTAT KNOB
200127	PVC HOSE D.35
200410	DRAIN OUTL.WASH.1 1/2"65X47X2
200412	GASKET DRAIN 11/2" 45X33X3
200469	STAND PIPE O RING 45X35,5X7
200491	BACK GASKET OF THERMOSTAT BOX
200927	GASKET FOR AIR TRAP
250806	TANK FILL HOSE CLAMP - AC/ACR
270101	HEXAGON LOCK NUT 1/2"
270104	LOCK NUT 1" 1/2
270107	BRASS LOCK NUT 3/8" FL803
270121	NUT FOR AIR TRAP
270409	DRAIN OUTLET AC-ACR
290217	HOSE CLAMP ELBOW 12X3/8" TYPE
323094	DOOR FRONT PANEL
333004	1300 WASH ZONE FILTER
333005	1300 WASH ZONE CENTRAL FILTER
343528	FASCIA CAPOT PARASPRUZZI LAV
350496	HEAT RECOVERY UNIT HOOD
351662	PANEL LAV
352046	UPPER PANEL
352047	LOWER PANEL
380836	OVERFLOW PIPE MM.415
411002	PERMANENT MAGNET 24X12
440907	SIPHON 1"1/2
450135	CLAMP FE ZN. 44-56 H=12,2
450137	COLLAR CONNECTION WITH BASE 31
450143	CLAMP D.39,7 X 37,7
450315	KNOB F. THERMOSTAT 90Ø
450516	THERMOSTAT SHIELD FOR 2 TERMOS
460501	GASKET 24X17X2
460502	GASKET 30X21X2
630948	COIL Z610A 24V 50/60-L180V01

# 4 - Wash/Rinse column 1300

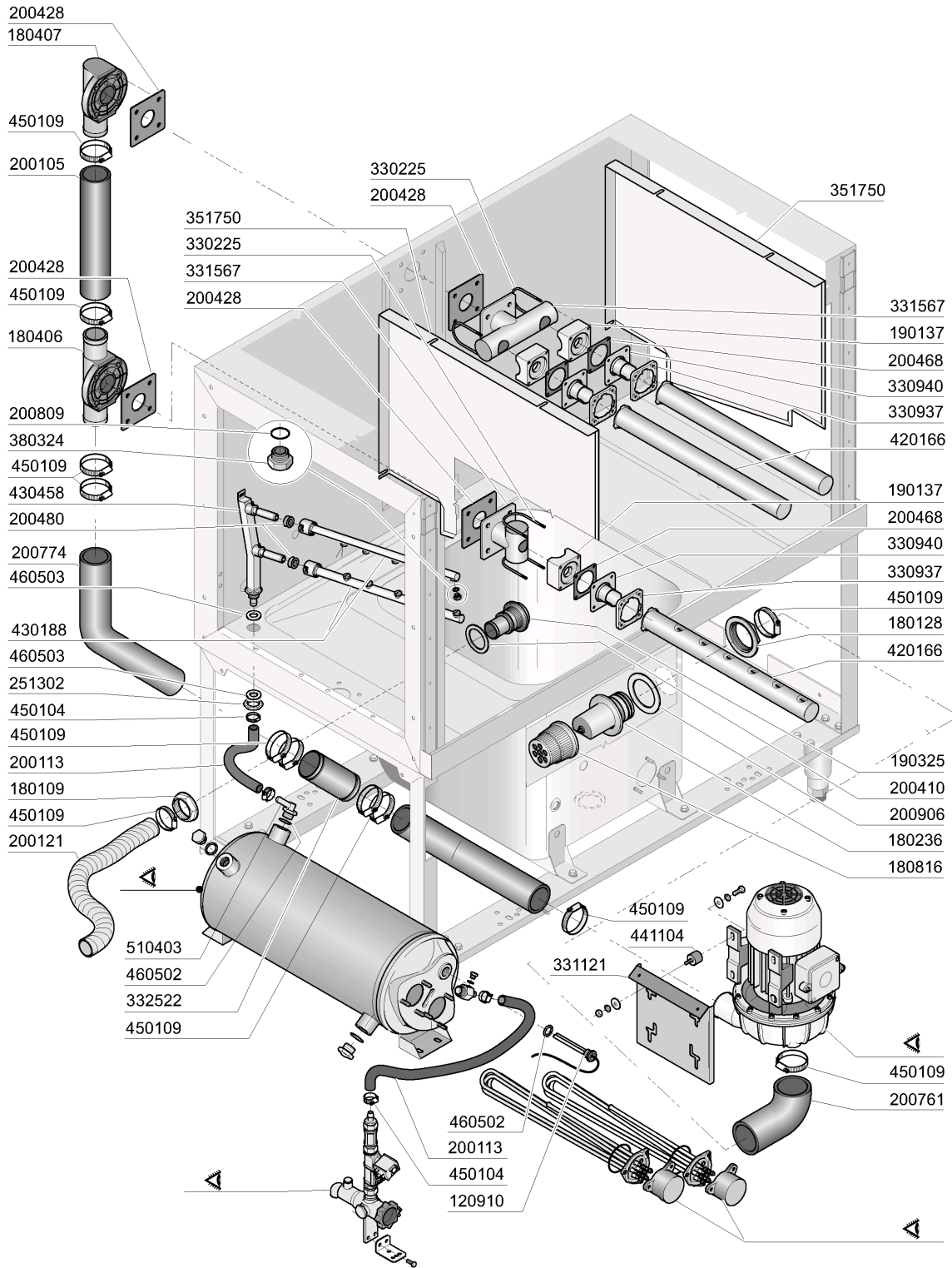

M.G. 10/08

4 - Wash/Rinse column 1300

CODE	DESCRIPTION
120910	ELECTRONIC TOUCH PAD CONTROLS
180109	LOCK NUT 1 1/2"
180128	RING NUT 65,4 C140 C85
180236	PUMP SUCTION FOR AC-ACR-C155
180406	T-CONNECTOR F. WASHING S90-SNL
180407	ELBOW S90 S N L
180816	STRAINER OF INLET PUMP AC-ACR
190137	WASH ARM SUPPORT ACR
190325	OVERFLOW CONNECTOR
200105	RUBBER HOSE 50X60
200113	RUBBER HOSE 12 X 22
200121	RUBBER HOSE 45X55
200410	DRAIN OUTL.WASH.1 1/2"65X47X2
200428	GASKET 100X100X3 NEOTEN
200468	GASKET 70X70X3 NEOTEN NE
200480	GASKET F. RINSE CONNECT.
200761	INLET HOSE - PREWASH AC -
200774	DELIVERY HOSE PREWASH AC
200809	OR GASKET 1,78X8,73X12,29
200906	GASKET D.92X66X2
251302	S/S LOCK NUT 3/4" AC-ACR
330225	TIE ROD ACR WASH ARM SUPPORT
330937	FLANGE
330940	FLANGE
331121	FIXING PLATE FOR PUMP ACR
331567	UPPER CONNECTION
332522	HOSE D48X1.5 L=100
351750	INTERMEDIATE PANEL
380324	RINSE JETS 52,5 80Ø OV1/8"
420166	WASH ARM SE/1
430188	RINSE ARM LVP
430458	RINSE COLUMN LV
441104	VIBRATION-DAMPING FEET FOR ACR
450104	CLAMP FE ZN H=12,5 15-24
450109	CLAMP 50-65
460502	GASKET 30X21X2
460503	SEALING WASHER 38X27X2(3/4)
510403	CONNECT.HOSE 90Ø1/2"X12

# 5 - Blower Dryer hood 800

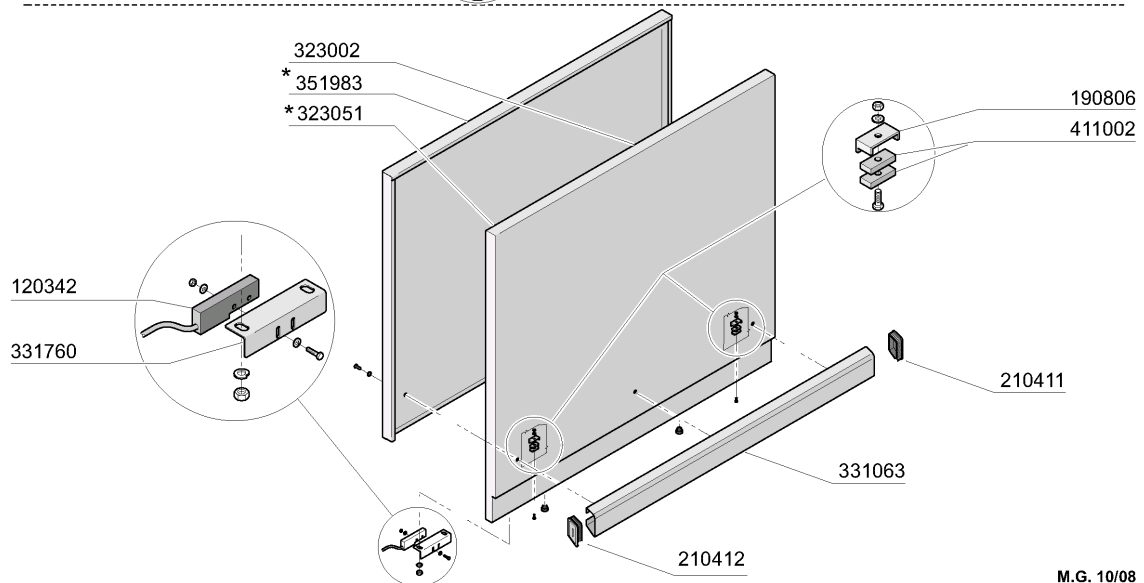
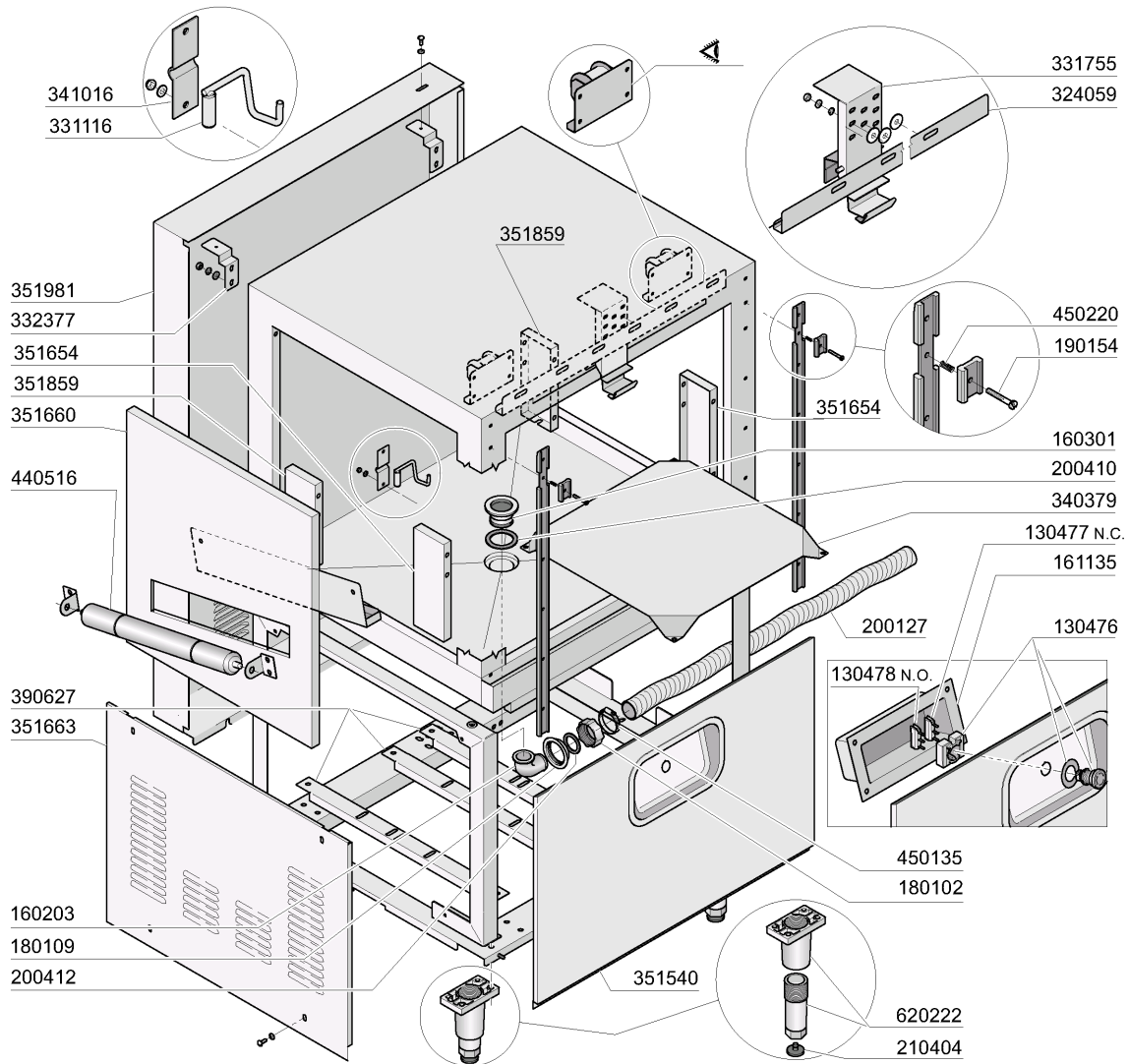

M.G. 10/08

## 5 - Blower Dryer hood 800

CODE	DESCRIPTION
120342	DOR MAGNETIC SWITCH
130476	ROTATIVE EMERGENCY SWITCH
130477	CONTACT NC
130478	CONTACT N.O.
160203	ELBOW 1"1/2 N-S-F-C /DRAIN
160301	DRAIN OUTLET 1"1/2 C-S-N
161135	PROTECTION FOR PUSH BUTTON NE
180102	DRAIN PIPE NUT 1"1/2 F45-55
180109	LOCK NUT 1 1/2"
190154	BRAKE
190806	MAGNET HOUSING
200127	PVC HOSE D.35
200410	DRAIN OUTL.WASH.1 1/2"65X47X2
200412	GASKET DRAIN 11/2" 45X33X3
210404	BLACK RUBBER FOOT S90 NE SE
210411	RIGHT PLUG FOR ACR/AC HANDLE
210412	LEFT PLUG FOR ACR/AC HANDLE
323002	DOOR 800MM
323051	DOOR 800 MM GMC
324059	SUPPORT
331063	800MM DOOR HANDLE
331116	DOOR SECURITY HOOK
331755	HOOK FOR DOOR SUPPORT
331760	BRACKET
332377	SQUADR.AGG.PANN.POST.AC/R/2001
340379	DRYER SPLASH SHIELD
341016	BRACKET FOR DOOR SECURITY HOOK
351540	EMERG. PUSH BUTTON FRONT PANEL
351654	PANEL LV
351660	PANEL LV
351663	PANEL LAV
351859	GUIDES SUPPORT
351981	BACK PANEL 800
351983	800 MM INSULATION PANEL
390627	PUMP SUPPORT
411002	PERMANENT MAGNET 24X12
440516	TRAY ROLLER
450135	CLAMP FE ZN. 44-56 H=12,2
450220	SPRING
620222	COMPLETE ALUMINIUM LEGS



6 - Blower Dryer 800

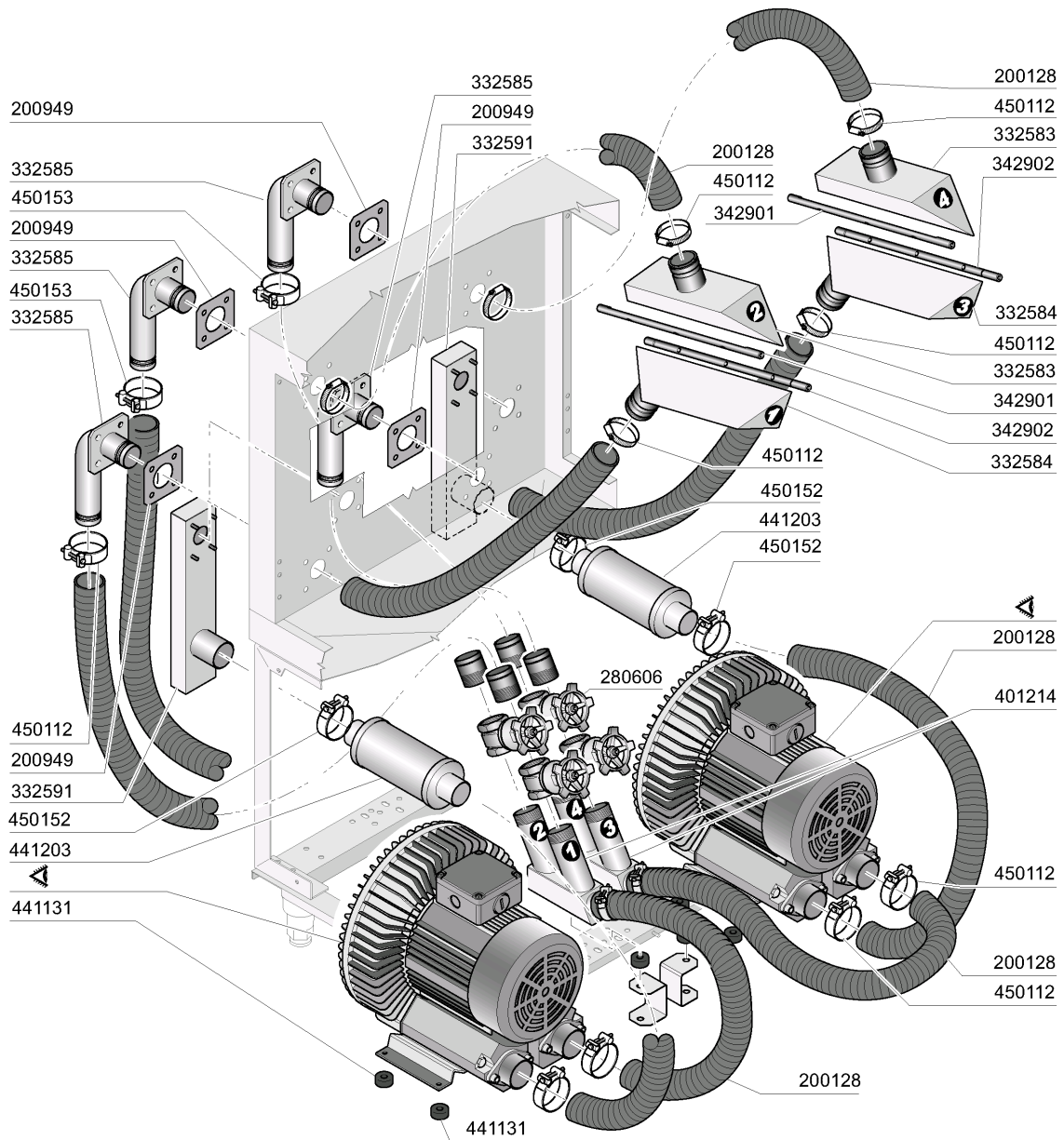

M.G. 10/08

**6 - Blower Dryer 800**

<b>CODE</b>	<b>DESCRIPTION</b>
200128	SUCTION HOSE
200949	JOINT 100X100X3
280606	GATE VALVE 1-1/2" BRASS
332583	UPPER AIR BREAKER
332584	LOWER AIR BREAKER
332585	WASH CONNECTION HOSE
332591	COLONNA ASPIRAZIONE LAV
342901	UPPER SHAFT
342902	LOWER SHAFT
401214	AIR COLLECTOR
441131	VIRATION- DAMPING 40X30X8
441203	FILTER
450112	FASC. STRING.ABA 110-138
450152	CLAMP 52-55 H23
450153	CLAMP 60-63 H23

## 7 - Polycord e pulegge

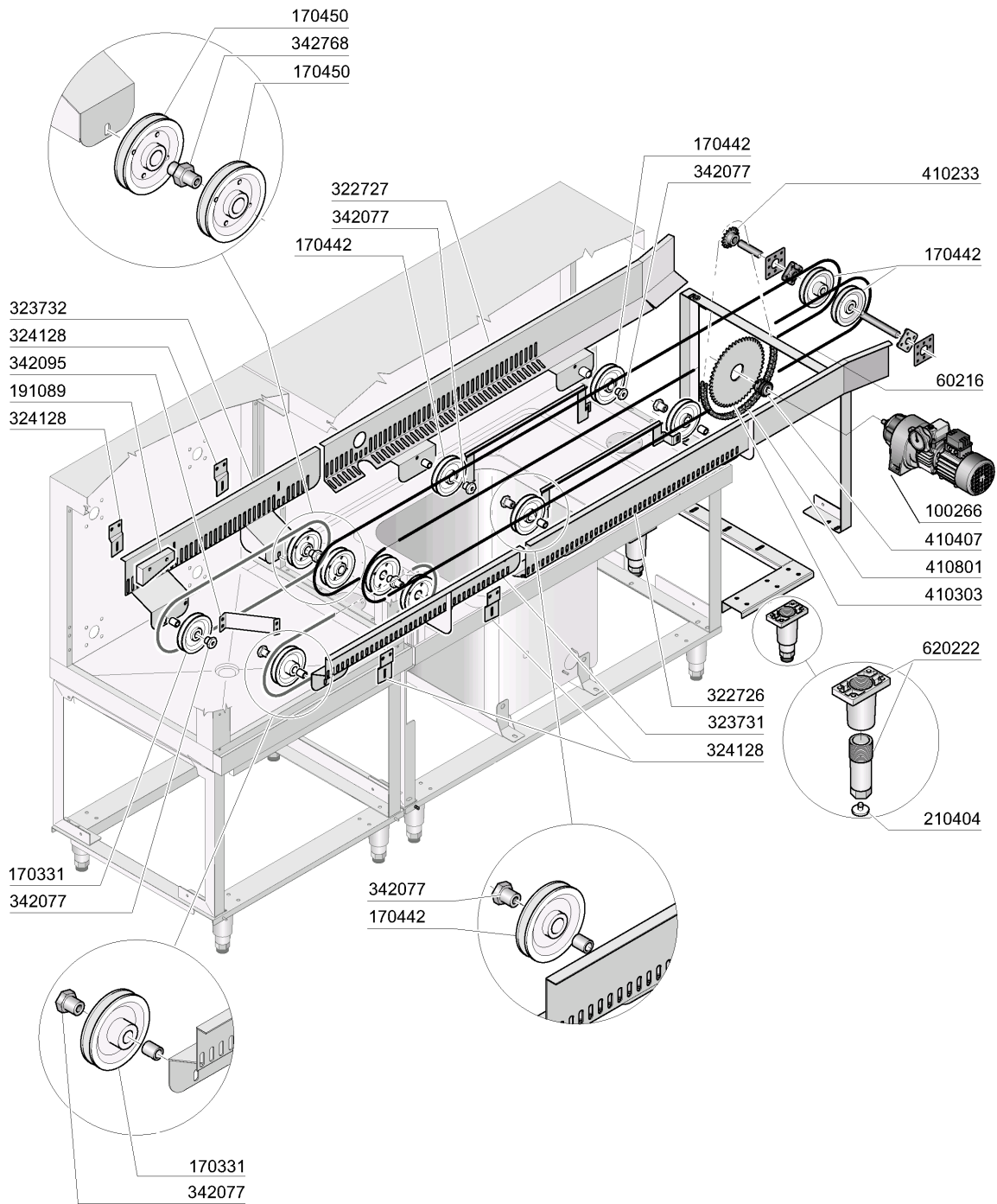

M.G. 10/08

## 7 - Polycord e pulegge

CODE	DESCRIPTION
100266	VARIABLE SPEED REDUCER 0,22KW
170331	PULLEY FOR POLYCORD
170442	WHEEL FOR POLYCORD
170450	WHEEL
191089	SCIVOLO PER VASSOI IN POLIZENE
210404	BLACK RUBBER FOOT S90 NE SE
322726	FRONT TRAYS GUIDE
322727	BACK TRAYS GUIDE
323731	FRONT GUIDE FOR DRYER 800
323732	BACK GUIDE FOR DRYER 800
324128	BRACKET
342077	PIN
342095	SPACER FLIGHT
342768	PIN
410233	TURNED PINION Z14-1/2"-D.17
410303	CROWN DISCS 50T 1/2" PITCH
410407	TORQUE LIMITER LC 1
410801	DRIVE CHAIN 1/2" N-S
60216	CORD OF POLYCORD D.12MM
620222	COMPLETE ALUMINIUM LEGS

## 8 - Molle, pompe, resistenze, soffianti

Molle porte	Ressort porte	Door counterbalance	Federn	Muelle
* <b>Modello</b> Doppia parete Double skin Double paroi Doppelwandig Dobla pared		Lavaggio Lavage Wash Waschzone Lavado 1300	Asciugatura Sechage Dryer Trocknung Secado 400	Asciugatura Sechage Dryer Trocknung Secado 800
<b>LAV1001</b>		2x5 Kg * 2x4 Kg 2x4,5 Kg		2x3,5 Kg * 2x5 Kg
<b>LAV1501</b>		2x5 Kg * 2x4 Kg 2x4,5 Kg	/ * 2x2,5 Kg	2x3,5 Kg * 2x5 Kg

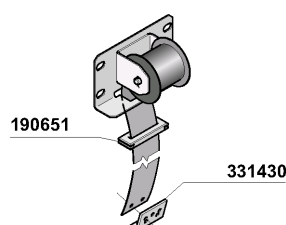

2,5 Kg > code = 391315  
3,5 Kg > code = 391317  
4 Kg > code = 391309  
4,5 Kg > code = 391318  
5 Kg > code = 391332

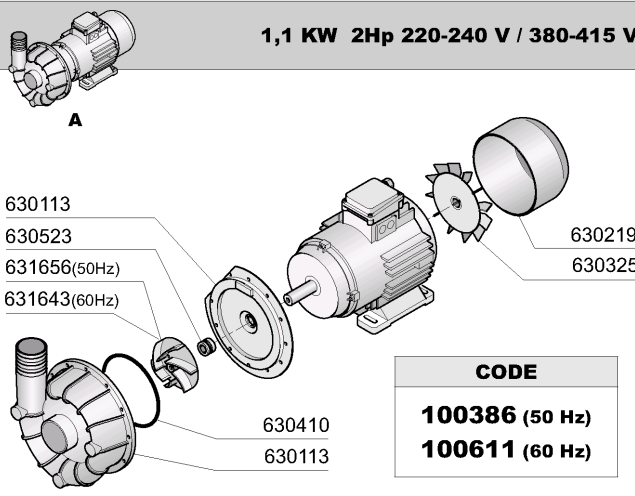

**1,1 KW 2Hp 220-240 V / 380-415 V**

CODE	
<b>100386</b>	(50 Hz)
<b>100611</b>	(60 Hz)

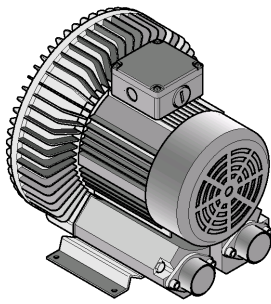

code 100541 (LAV1501)  
4KW 230V/400V 50/60Hz **C**

code 100545 (LAV1001)  
2,2 KW 230V/400V 50/60Hz **B**

	230V/3		50/60 Hz		400V/3N		50/60 Hz		
	Pompa Pompe Pump Pumpe Bomba	Teleruttore Contacteur Contactor Schaltschütz Contactor	Magnetotermici Magneto-termique Termo-magnetic Magnetischer schalter Magneto-termico		Teleruttore Contacteur Contactor Schaltschütz Contactor	Magnetotermici Magneto-termique Termo-magnetic Magnetischer schalter Magneto-termico			
	Kw	A	cod.	A	cod.	A	cod.	cod.	
<b>A</b>	1,1	9	120468	4 + 6	120824	9	120428	17 + 2,4	120822
<b>B</b>	2,2	16	120470	10 + 13	120826	12	120469	4 + 6	120824
<b>C</b>	4	20	120470	10 + 13	120826	16	120470	5,5 + 8	120825

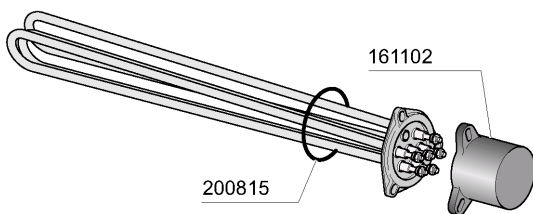
Resistenze	Resistances	Heating elements	Heizungen	Resistencia
			4,2 Kw	110331
			5 Kw	110371
			6 Kw	110349
			8 Kw	110343
			9 Kw	110362
			10 Kw	110388

M.G. 10/08

## 8 - Molle,pompe,resistenze,soffianti

CODE	DESCRIPTION
100386	PUMP HP 1,5 220/380/50 1219
100541	VENTILATOR FOR DRYER LVP 4KW
100545	FAN 2.2KW 2.ND DRYER TRAY WASH
100611	PUMP HP 1,5 380/3/60HZ F1219
110331	HEAT.ELEMENT 4200W 230/400V
110343	HEAT.ELEM. 8000W 220/380V
110349	HEAT.ELEMENT 6000W 230/400V
110362	HEAT.ELEMENT 9000W 220/380V
110371	HEAT.ELEMENT 5000W 220/380V
110388	HEAT.ELEMENT 10000W 230/400V
120428	CONTACTOR 9A 24V 50HZ
120468	CONTACTOR ABB 9A 24V 50/60HZ
120469	CONTACTOR ABB 12A 24V 50/60HZ
120470	CONTACTOR ABB 16A 24V 50/60HZ
120822	OVERLOAD RELAY 1,6-2,5A
120824	OVERLOAD RELAY 4/6 A
120825	OVERLOAD RELAY 5,5/8 A
120826	OVERLOAD RELAY 10/13A
161102	ELEMENT COVER MOPL.
190651	BUSH
200815	O-RING F. HEAT.ELEM.
331430	BRACKET FOR DOOR SPRING
391309	DOOR SPRING 4KG - 40MM
391315	DOOR SPRING 2,5KG - 40MM
391317	DOOR SPRING 3,5KG - 40MM
391318	DOOR SPRING 4,5KG - 40MM
391332	DOOR SPRING 5,5 KG - 40MM
630113	VOLUTE FIR HP0,5-1,55
630219	FAN HOUSING FIR HP.0,75-1
630325	COOLING FAN F.PUMP 1219/2241
630410	O-RING PUMP FI HP0,5-0,75-1
630523	SEAL FOR PUMP FIR1219
631643	IMPELLER HP1/1,5 60HZD.90-1219
631656	PUMP IMPELLER 1HP - 2255

## 9 - Recovery unit

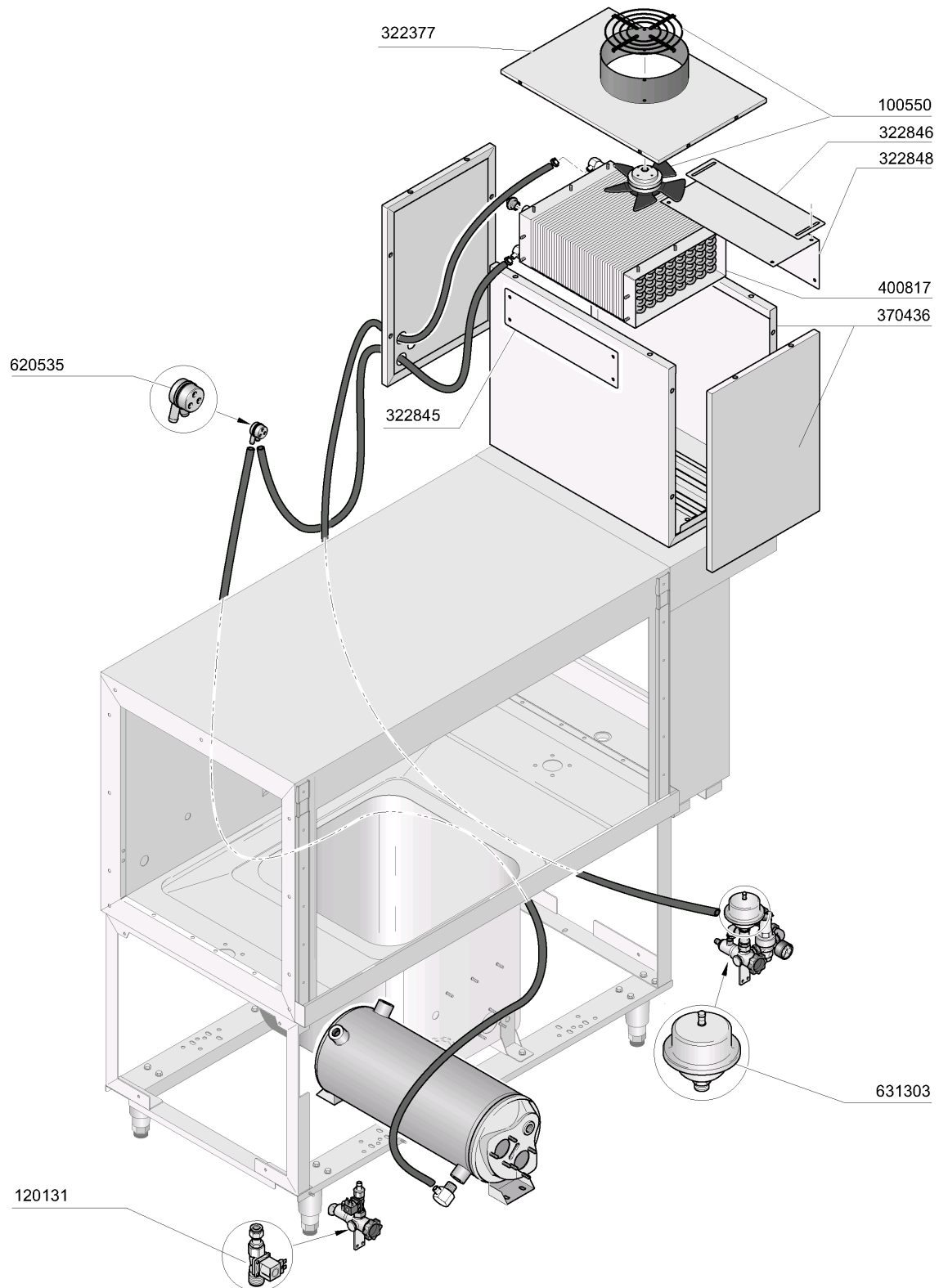

M.G. 10/08

9 - Recovery unit

CODE	DESCRIPTION
100550	FAN FOR HEAT RECOVERY UNIT
120131	SOLE. L182Q31-ZB10A 1/2"24V
322377	COVER
322845	COVER
322846	COVER
322848	COVER
370436	HOOD
400817	BATTERY FOR STEAM CONDENSER +
620535	VACUUM BREAKER
631303	HYDRAULIC AIR VESSEL FOR HEAT



# 10 - Control Box

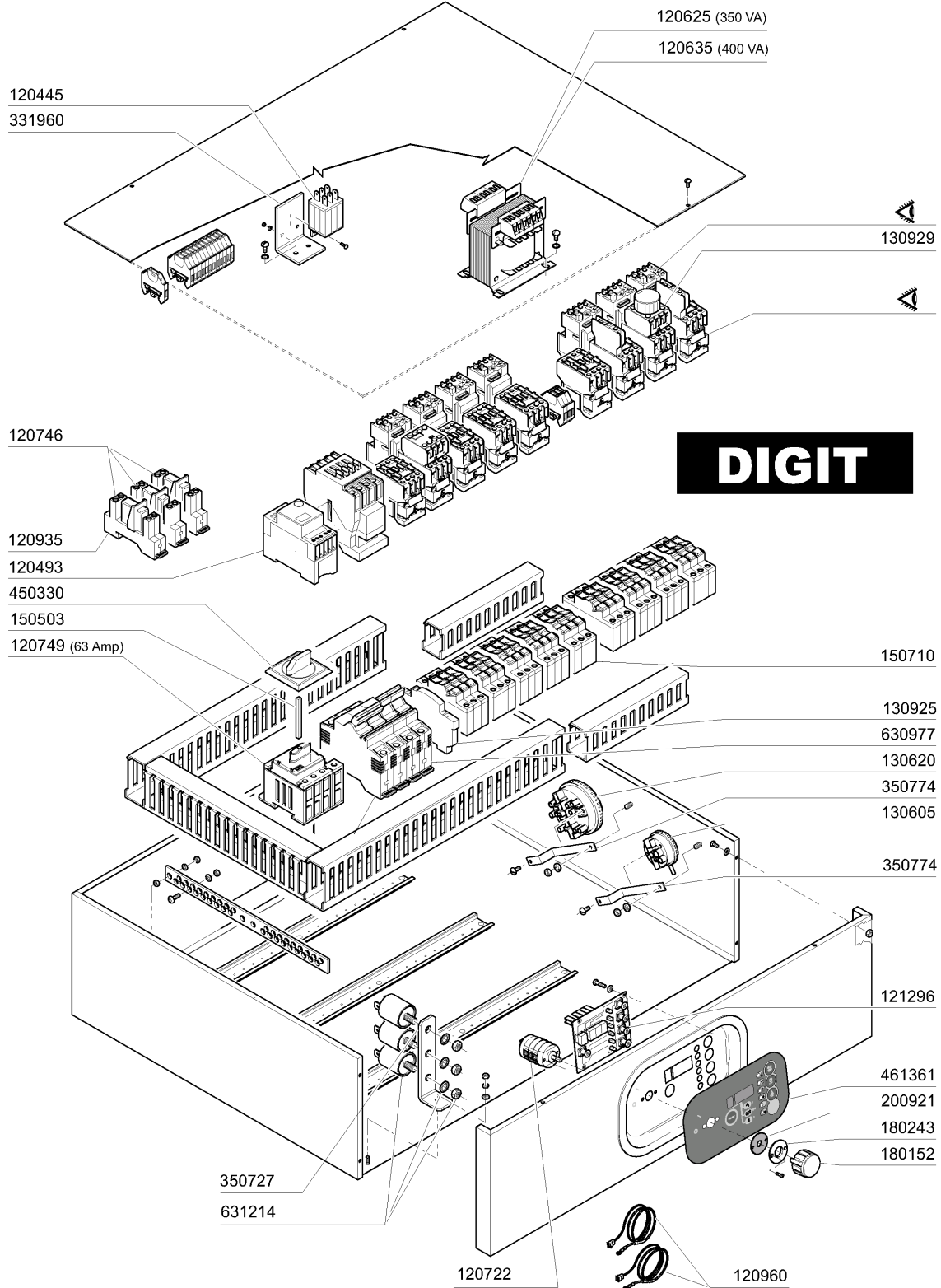

M.G. 10/08

## 10 - Control Box

CODE	DESCRIPTION
120445	AUXILIARY RELAY S.B2/3 24V
120493	RELAY 130180240000
120625	TRANSFOR.350VA 225*415/12V-24V
120635	TRANSFORMER 400VA220-240-380-4
120722	6 POLE SWITVH 2 POSITIONS
120746	SELECTOR WITH LIGHT RM650R
120749	MAINSWITCH 63A 4P
120935	SUPPORT
120960	PROBE C-G
121296	ELECTRONIC CONTROL PANEL
130605	PRESSURE SWITCH 50-30 1 LEVEL
130620	PRESSURE SWITCH 3 LEVEL 50-30/
130925	CONTACT FOR CIRCUIT BREAKER
130929	CONTACT ABB 1NO/1NC 30"
150503	EXTENTION FOR MAIN SWITCH
150710	FUSE CARRIER 10,3X38 ART.21401
180152	KNOB
180243	FLANGE
200921	GASKET
331960	BRACKET
350727	BRACKET
350774	BRACKET
450330	KNOB FOR MAIN SWITCH
461361	PLATE ACS101-242 DIGIT
630977	COIL FOR CIRCUIT BREAKER 24V
631214	ANTI-NOISE FILTER 4011135007 3

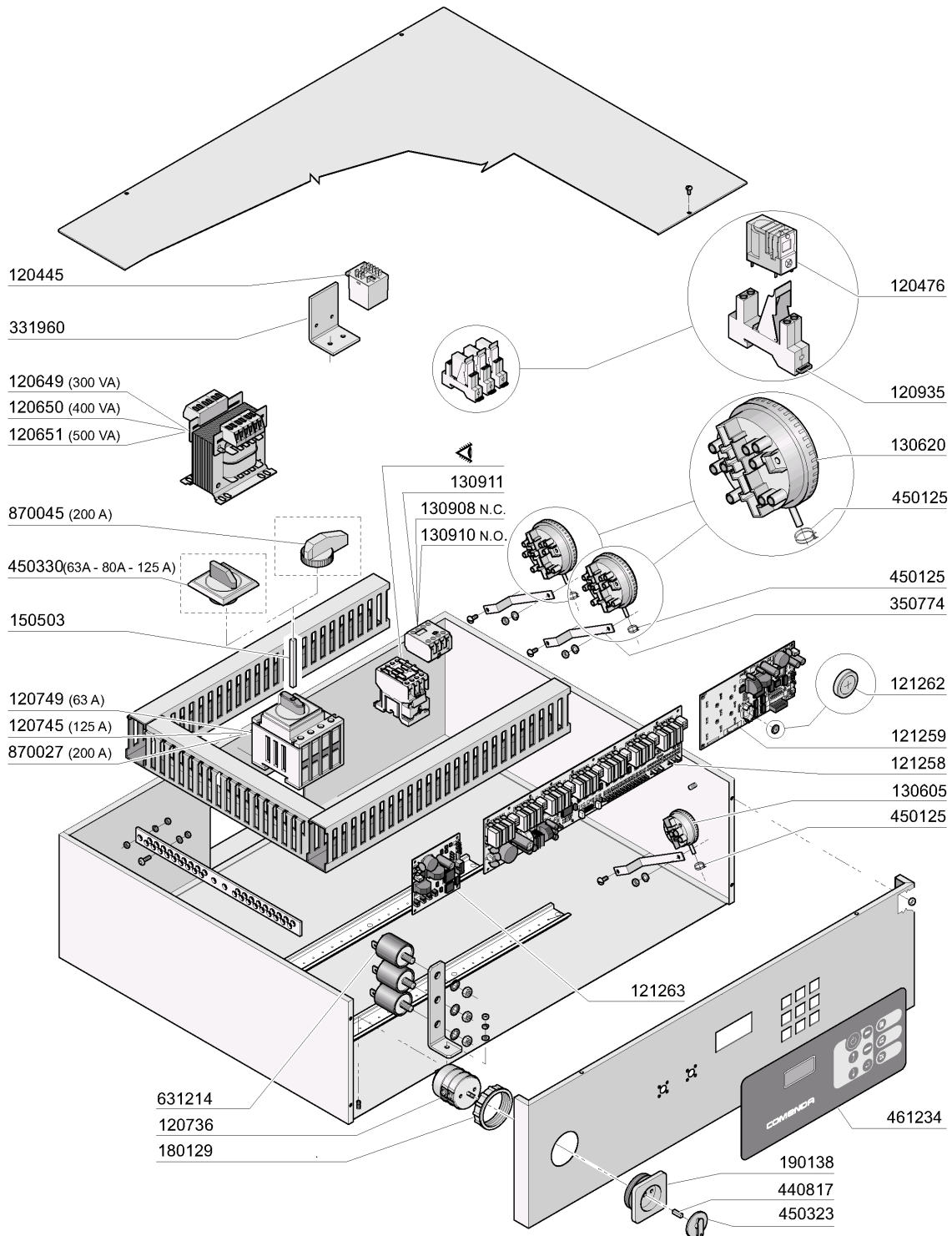

M.G. 10/08

11 - Control Box -E3-

CODE	DESCRIPTION
120445	AUXILIARY RELAY S.B2/3 24V
120476	RELAY 16A 24V
120649	TRANSFORMER 300VA225-240-380-4
120650	TRANSFORMER 400VA225-240-380-4
120651	TRANSFORMER 500VA225-240-380-4
120736	4 POLE MAIN SWITCH 25A 500V
120745	MAIN SWITCH 4 POLE 125A
120749	MAINSWITCH 63A 4P
120935	SUPPORT
121258	MAIN PCB E3
121259	KEYBOARD PCB
121262	LITHIUM BATTERY 3V.CR2450N
121263	HPS BOARD
130605	PRESSURE SWITCH 50-30 1 LEVEL
130620	PRESSURE SWITCH 3 LEVEL 50-30/
130908	AUXILIARY CONTACT LA1 DO2 A65
130910	CONTACT LA1 D20 A65
130911	CONTACT LA1 D40 A65
150503	EXTENTION FOR MAIN SWITCH
180129	NUT FOR MAIN SWITCH SUPPORT
190138	SUPPORT
331960	BRACKET
350774	BRACKET
440817	SNAP RING LSCB/1853/17/00
450125	ELASTIC CLAMP D. 10,4X9,8
450323	KNOB FOR BC-BR-C95-C155
450330	KNOB FOR MAIN SWITCH
461234	PLATE "ELECTRONIC 3"
631214	ANTI-NOISE FILTER 4011135007 3
870027	MAIN SWITCH 200A
870045	SWITCH FOR MAIN SWITCH 200A

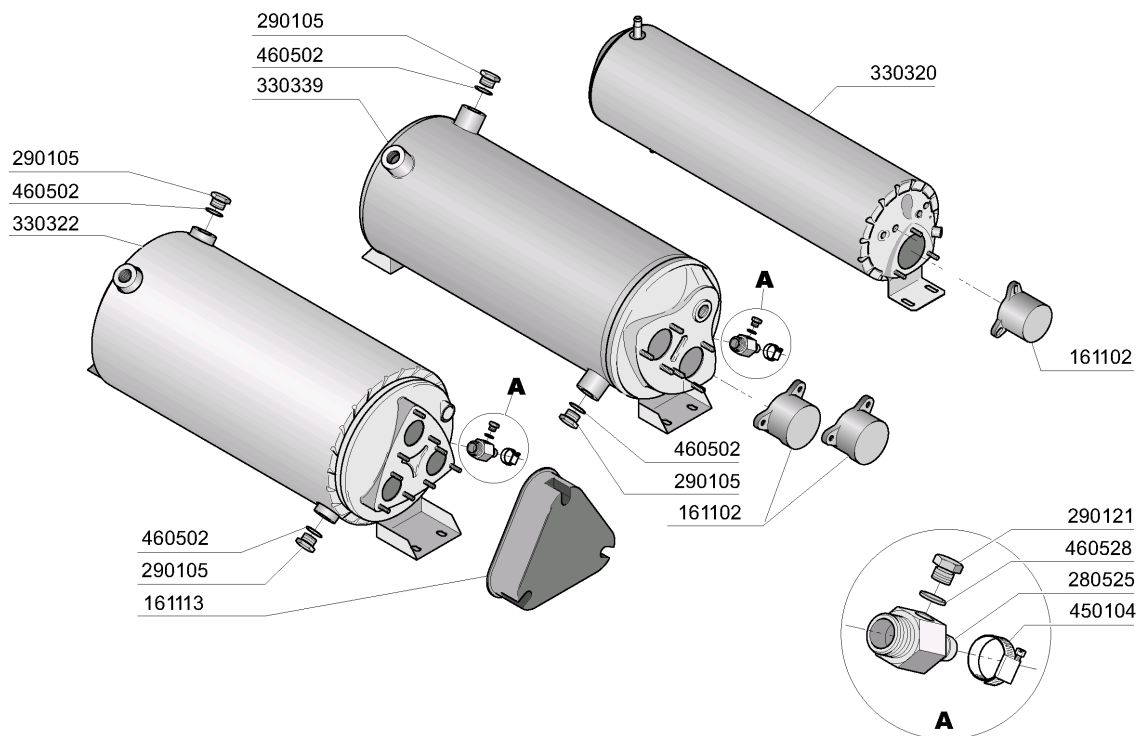
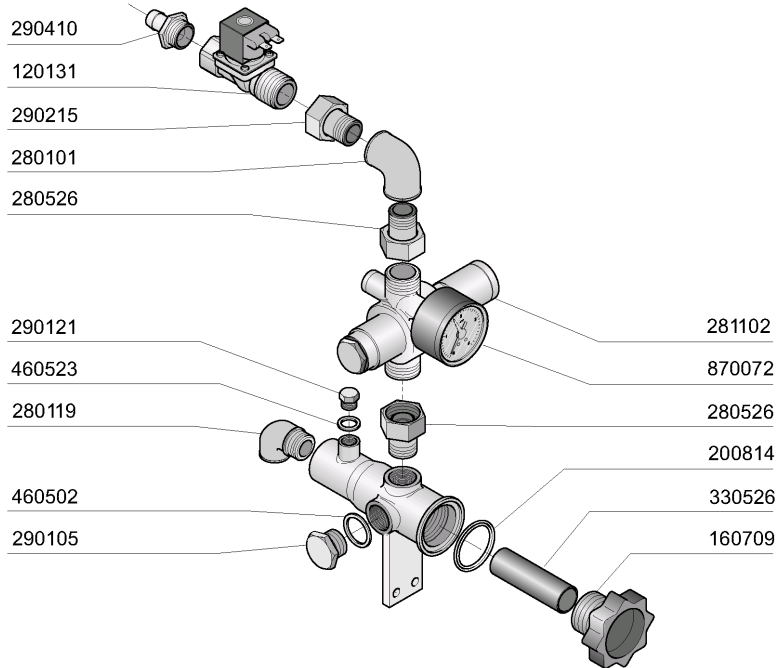

M.G. 10/08

## 12 - Riduttore e boiler

CODE	DESCRIPTION
120131	SOLEN. L182Q31-ZB10A 1/2"24V
160709	KNOB OF MANIFOLD F. SOLEN. VAL
161102	ELEMENT COVER MOPL.
161113	ELMENT COVER BLACK
200814	O-RING 34,52X41,58X3,53
280101	CRANK F.F 1/2"
280119	ELL MF 3/4"
280525	NIPPLE
280526	CONNECTION 1/2-3/4"
281102	1/2" ADJ VALVE C/W GAUGE TYPE
290105	BRASS-TE-PLUG 1/2"
290121	BRASS PLUG 1/8"
290215	1/2"BSP M/F UNION BRASS
290410	NIPPLE 1/2"
330320	INSULATED BOILER D.1 164X650 S
330322	INSULATED BOILER D.230 N/S
330339	BOILER D.220X640 F.TWO HEAT.EL
330526	FILTERS 22X28 SOLENOID V.MANIF
450104	CLAMP FE ZN H=12,5 15-24
460502	GASKET 30X21X2
460523	GASKET 10X18X2
460528	GASKET 15X10X2 FOR RINSE NIPPE
870072	PRESSURE CAUGE 0-4 ATM

13 - beckpt tray accumulator

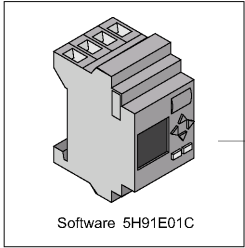

121272

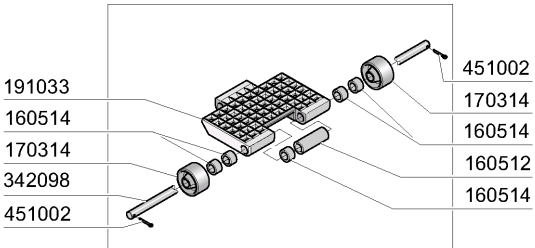

322687

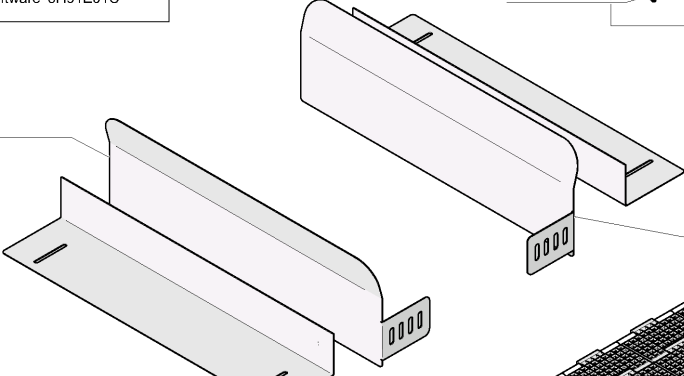

322686

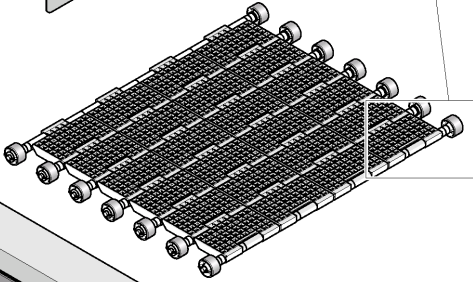

440503

342808

332325

322844

322711

341041

332323

341050

450217

322711

341041

332323

341050

450217

120907

**13 - beakup tray accumulator**

<b>CODE</b>	<b>DESCRIPTION</b>
120907	PHOTOCELL F.TRAY WASHER E3FDS-
121272	PLC
160512	SPACER 35,5
160514	SPACER 7,9 108378 MOP
170314	GRAY BELTWHEEL N
191033	GRID F. BELT OF CUTLERY
322686	GUIDA LATERALE DX X RECEVOIR
322687	GUIDA LATERALE SX X RECEVOIR
322711	RIGHT RAIL GE
322844	LOWER COVER
332323	SPRING BRACKET
332325	BRACKET
341041	RAIL
341050	RAIL
342098	SHAFT
342808	TABLE
440503	ROLLERS F.SLAT BELT 1062V
450217	SPRING F.DOOR G65/115
451002	COTTER PIN STAINL.ST. D2X12